

## Provider Notification Table of Contents

<b>23. PROVIDER NOTIFICATION .....</b>	<b>2</b>
23.1 BUSINESS MODEL .....	2
23.1.1 Push Transaction Process .....	2
23.1.2 Pull Transaction Process .....	2
23.2 PROVIDER NOTIFICATION SCHEMA .....	3

## 23. Provider Notification

### 23.1 Business Model

#### Provider Notification (PN) Normal Transaction Flow

The following diagram depicts a normal Provider Notification (PN) transaction flow. A normal transaction flow means:

- Outbound only transaction from Qwest
- Transaction information contains loss notification for only one WTN or ECCKT.

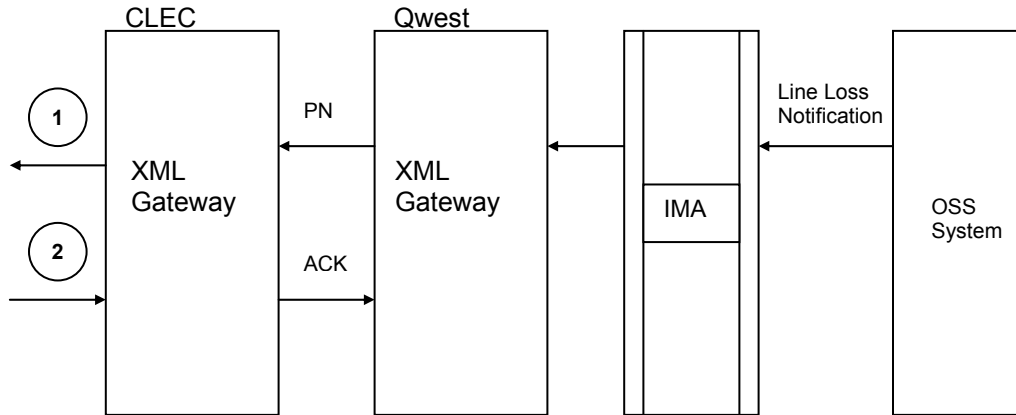

#### 23.1.1 Push Transaction Process

1. After CLEC subscription to the Line Loss Notification (PN) is verified, the RSL system initiates a Line Loss Notification message to Interconnect Mediated Access (IMA). The IMA gateway is a middleware that performs order content edits and interacts with the Operating Support System (OSS). The IMA gateway formats and forwards the Line Loss message to the Qwest IMA XML Gateway. Qwest opens an asynchronous connection to the CLEC and then transports the transaction to the CLEC's XML Gateway.
2. An Acknowledgment from the CLEC will be returned to the Qwest IMA XML Gateway to confirm receipt of the PN transaction. If an Acknowledgment is not returned the PN transactions will be made available for Pull.

#### 23.1.2 Pull Transaction Process

1. After CLEC subscription to the Line Loss Notification (PN) is verified, the RSL system initiates a Loss Notification message to Interconnect Mediated Access (IMA). The IMA gateway formats and forwards the Line Loss message to the IMA XML Gateway, where the transaction will be available to be pulled.
2. The CLEC will initiate a Pull request for up to the maximum number of notices. The Pull request will retrieve all post-order notices waiting to be pulled.
3. The CLEC will send an individual acknowledgement to the Qwest IMA XML Gateway for each transaction they pick up. If an acknowledgement is not received within 24 hours the PN will be made available for Pull again the next day. This process will be repeated until an acknowledgement is received.

## **23.2 Provider Notification Schema**

Please see Appendix H – WSDL – Post Order.